

STANDARD SINKITS CLAMP FACT SHEET

TOP BOLT: TIGHTEN AGAINST SINK RIM TO COMPLETE INSTALLATION. DO NOT OVER-TIGHTEN.



MADE AND SOURCED
IN THE USA



SAVES TIME CREATING PROFIT,
EVEN WITH A LOW VOLUME OF
SINK INSTALLATIONS

REDUCES ERRORS AND
CALL-BACKS

NO ADHESIVES OR EPOXY

EASILY SUPPORT HUNDREDS OF
POUNDS

ZINC TRIVALENT COATING

WORKS ON 2CM AND 3CM

BINDING TAB: PREVENTS THE TOP BOLT FROM "WALKING" ON THE SINK RIM DURING TIGHTENING. THIS TAB ALLOWS FOR THE CLAMP TO STAY IN PLACE, USING THE WEIGHT OF THE SINK, AFTER INSERTING THE ANCHOR POST. IT MUST BE BENT FAR ENOUGH TO CREATE PRESSURE WHEN INSERTING.

ANCHOR POST: 1 1/8" LENGTH AS THE 1 1/4" BOLT TRAVELS THROUGH THE CLAMP BODY. STANDARD LENGTH SINKITS CAN BE USED ON UP TO 7/8" SINK RIMS. SINKITS XL CLAMPS WILL WORK UP TO 1 1/8" SINK RIMS.

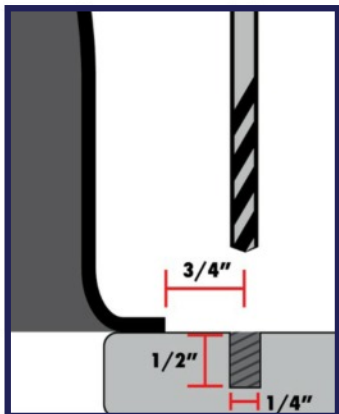

HOLE SPECIFICATIONS: USING A 1/4" BIT ON A DRILL WITH A MINIMUM SPEED OF 3000 RPMs, BORE AT LEAST A 1/2" DEEP HOLE 3/4" FROM THE EDGE OF THE SINK RIM. MAY BORE HOLE UP TO 3/4" DEEP ON 3CM COUNTERTOPS.

Distributed by:



706-213-7715

www.levisinkco.com